



# KB300 Baby Changing Station

## Technical Data Sheet

---

### Color

- KB300-00 Beige
- KB300-01 Grey
- KB300-05 White Granite

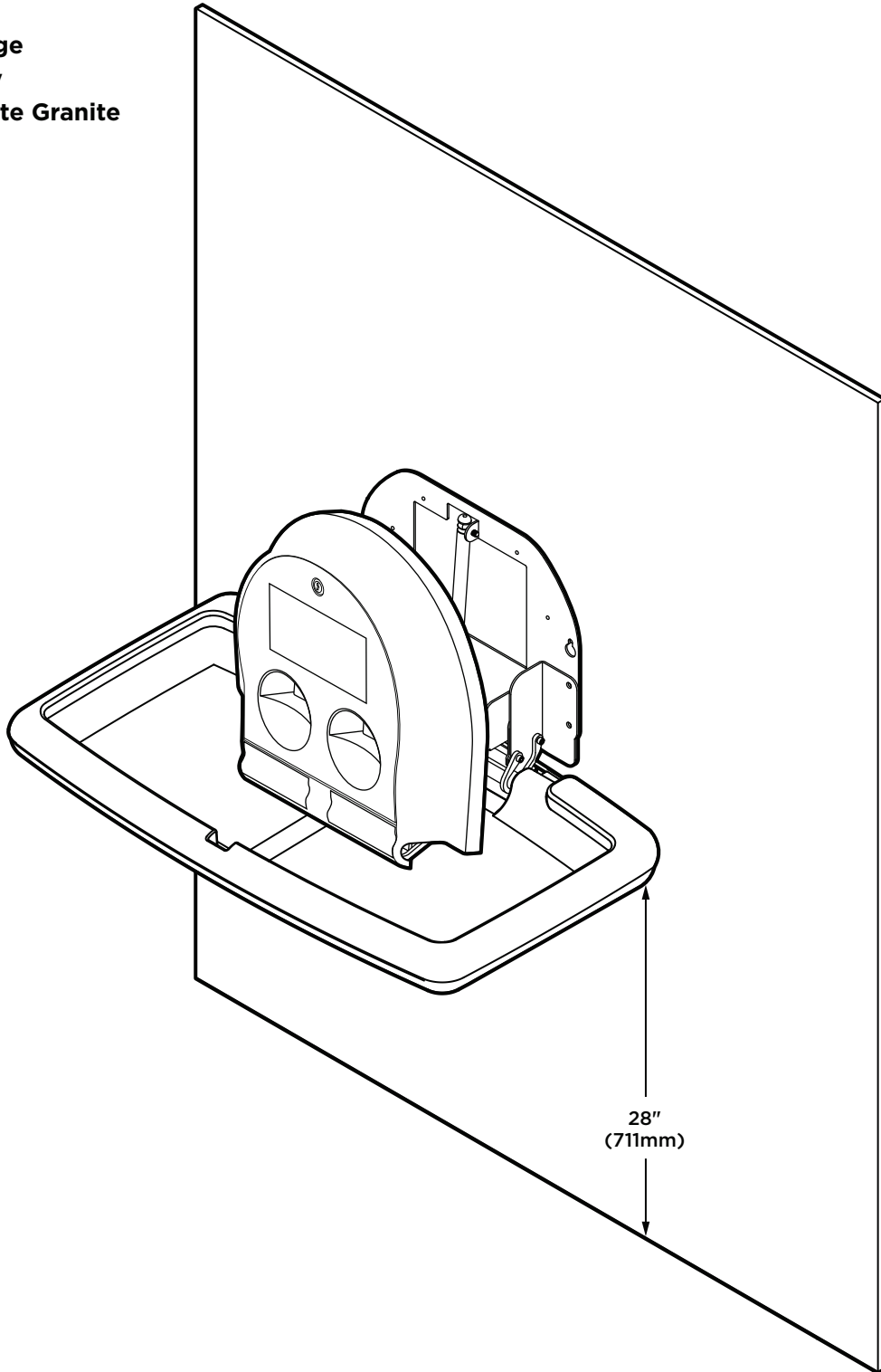

\*Diagrams are not to scale.



# KB300 Baby Changing Station

## Closed Position

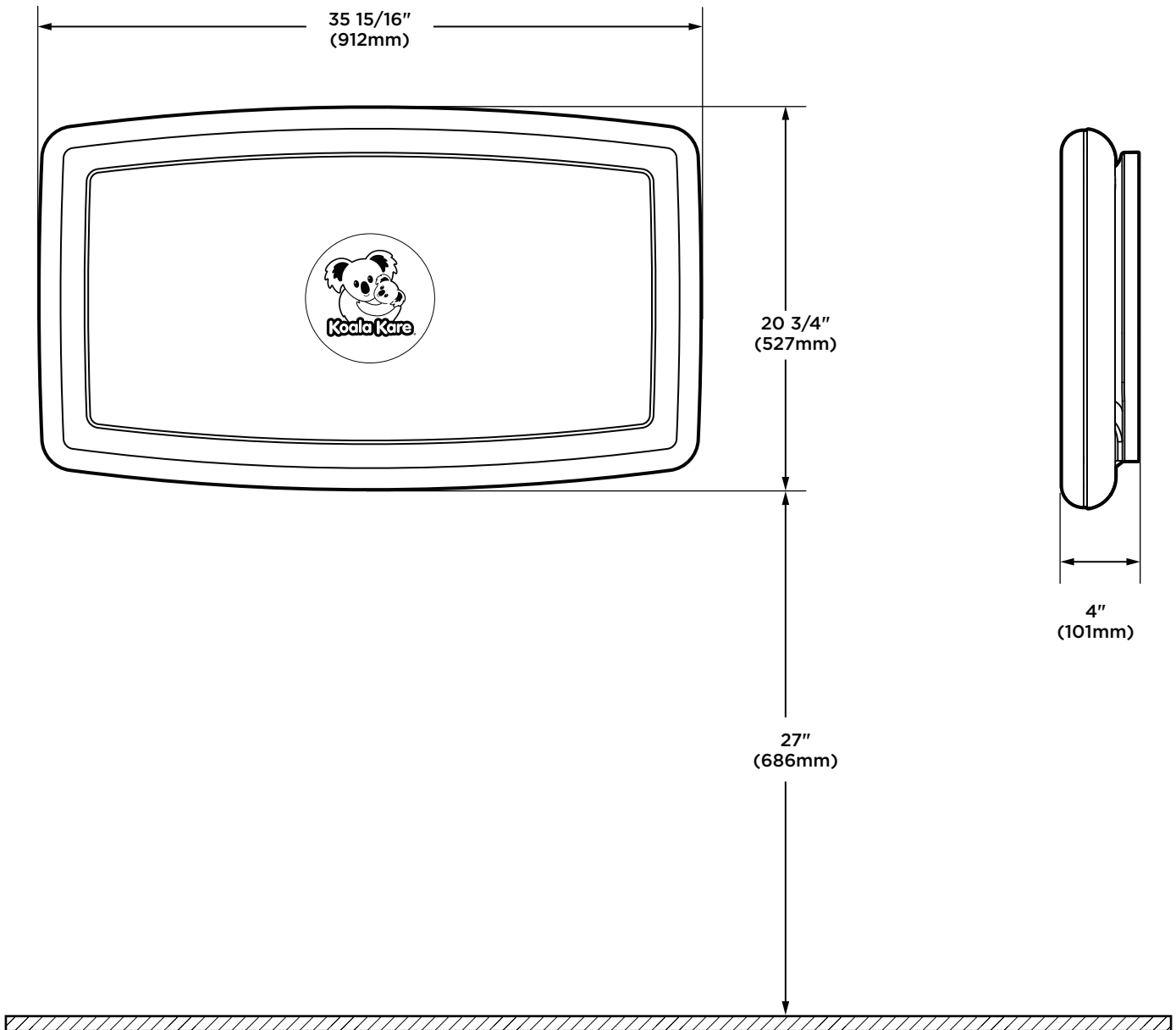

\*Diagrams are not to scale.



# KB300 Baby Changing Station

## Open Position

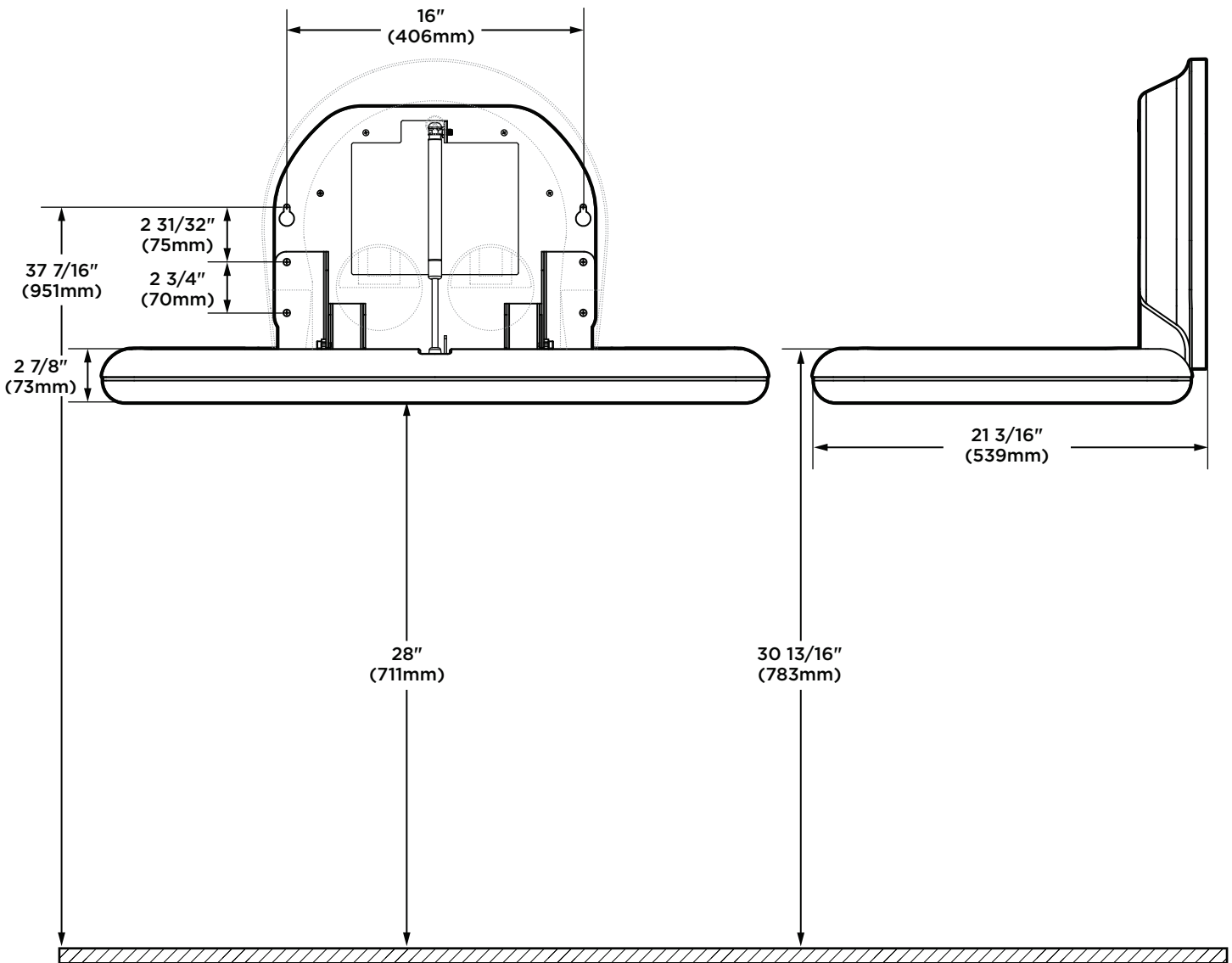

\*Diagrams are not to scale.



# KB300 Baby Changing Station Information

---

## Material

Injection-molded polypropylene with Microban® antimicrobial additive embedded into the bed surface. Reinforced steel-on-steel hinge mechanism and metal mounting chassis with mounting hardware included. Labeled usage instructions and safety messages in four languages. Optional Braille label available. Contoured changing surface area is 535 sq. in (3452 sq. cm) and comes complete with impervious TPU safety strap. Dual cavity liner dispenser holds approximately 50 KB150-99 bed liners.

## Operation

Concealed pneumatic cylinder and metal mounting chassis provides controlled, slow opening and closing of bed. Polypropylene is easy to clean and resists odors and bacterial growth. Complies with ASTM static load performance requirements when properly installed. Internal liner dispenser with integrated spring tab dispensed one liner at a time.

**Warning:** To ensure that the unit supports the intended loads, baby changing stations must be properly installed according to the manufacturer's instructions.

## Specification

Baby changing station body shall be durable, injection-molded polypropylene. Design of unit shall be surface-mounted. Unit shall be equipped with a pneumatic cylinder for controlled opening and closing of bed. Bed shall be secured to metal mounting chassis with a concealed steel-on-steel hinge. No hinge structure shall be exposed on interior or exterior surfaces. Unit shall have mounting hardware included. Unit shall have Microban® antimicrobial embedded into plastic material on the changing surface. Unit shall comply with ADA regulations when properly installed. Bed shall have smooth concave changing area with a safety strap.

The design and manufacture of Koala products is intended to be compliant with the 2010 ADA Standards for Accessible Design and the 2009 ICC A117.1, Accessible and Usable Buildings and Facilities. Unit shall conform to ASTM F2285-04(16) Standard Safety Performance Specification for Diaper Changing Tables for Commercial Use, ANSI Z535.4 Product Safety Signs and Labels, EN 12221:2008+A1: 2013. Unit shall have a built-in Liner Dispenser for use with 3-ply chemical free biodegradable bed liners, instructional graphics and safety messages in 4 languages. Unit shall be backed by manufacturer's 5-year limited warranty on materials and workmanship and include a provision for replacement caused by vandalism.

Unit shall be manufactured in the U.S.A.

## ADA Requirements

Additional information on how this product complies with ADA requirements can be found in the *KB300 & KB301 Baby Changing Stations Accessibility Compliance* document on [www.koalabear.com](http://www.koalabear.com).

*The illustrations and descriptions herein are applicable to production as of the date of this Technical Data Sheet. The manufacturer reserves the right to, and does from time to time, make changes and improvements in designs and dimensions without notice.*

**Koala Kare Products**  
**A Division of Bobrick**

6982 South Quentin Street, Centennial, CO 80112-3945  
**Main:** 303.539.8300 | **Toll Free:** 888.733.3456 | **Fax:** 303.539.8399  
**Website:** koalabear.com | **Email:** customerservice@koalabear.com